

Type VT-U smd ceramic kovar package (1.5 ~ 52.0)MHz

- # tight symmetry
- # (7.0 x 5.0)mm footprint
- # +3.3Vd.c., +5.0Vd.c. supply

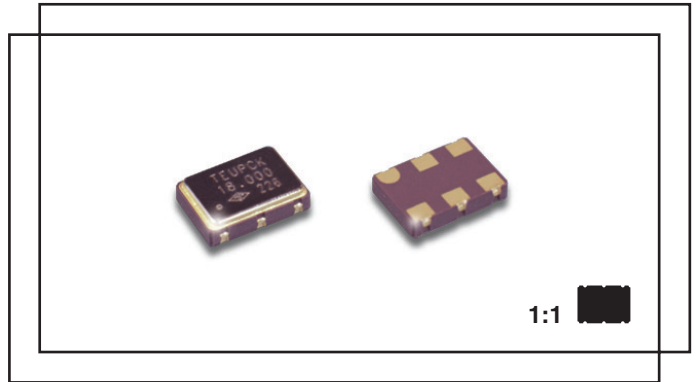

Electrical specification

Case style	T: (7.0 x 5.0)mm, height 2.0mm		
Frequency range	(1.5 ~ 52.0)MHz		
Stability *	±(25 ~ 50)ppm, temperature range dependent		
Pulling range	±100ppm min.		
Control voltage V_t	(±2.5 ±2.0)Vd.c., $V_{cc} = +5.0Vd.c.$, (+1.65 ±1.35)Vd.c., $V_{cc} = +3.3Vd.c.$		
Supply voltage V_{cc}		+3.3Vd.c.	+5.0Vd.c.
Supply current max.	(1.5 ~ 20)MHz	10mA	15mA
	(20 ~ 47)MHz	20mA	40mA
Rise and fall time max. **	(1.5 ~ 20)MHz	10ns	8ns
	(20 ~ 47)MHz	6ns	5ns
Operating temperature	(-20 +70)°C ~ (-40 +85)°C		
Storage temperature	(-40 +125)°C		
Output	CMOS 15pF, CMOS 50pF		
Symmetry	(45 ~ 55)%, (40 ~ 60)%		
Ageing	±5ppm first year max.		

* inclusive of calibration tolerance at +25°C, temperature tolerance, supply voltage variation, load variation, first year ageing, shock and vibration.

** measured, with an output load of 15pF, between (10 ~ 90)% V_{cc}

Ordering information

Example type VT-U smd clock oscillator, 40.00MHz, ±100ppm pulling range, +3.3Vd.c., ±25ppm(-20 +70)°C, output CMOS 15pF, symmetry (45 ~ 55)%

TFC PART NUMBER VT 40.0M E U M C J

'VT' type number: VT = smd clock oscillator type VT

'40.0M' frequency: 40.0M = 40.00MHz, frequency range from (1.5 ~ 52.0)MHz

'E' supply voltage: E = +3.3Vd.c., C = +5.0Vd.c.

'U' VCXO designator

'M' frequency stability: M = ±25ppm

'C' temperature range: C = (-20 +70)°C

'J' output logic and symmetry: J = CMOS 15pF, (45 ~ 55)%

Frequency stability M: ±25ppm, P: ±50ppm,

Temperature range C: (-20 +70)°C, L: (-40 +85)°C

Output J: CMOS 15pF(45 ~ 55)%, F: CMOS 50pF(45 ~ 55)%,

K: CMOS 15pF(40 ~ 60)%, G: CMOS 50pF(40 ~ 60)%

Type VT-U

VT-U dimensions(mm) shown twice full size

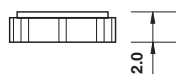
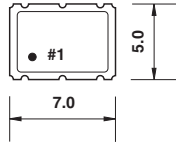

Suggested land pattern

Pads are gold, 2.5 μ min., over nickel, suitable for vapour phase or reflow soldering, preheat +150°C for 2 minutes, peak temperature +250°C for 30 seconds max.

Connect 0.01 μ F capacitor between Vcc and ground

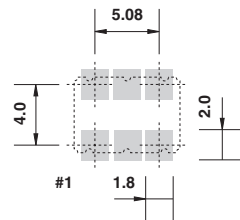
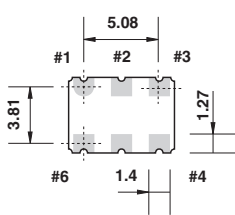

Pads viewed from bottom

- #1 voltage control
- #2 output inhibit
- #3 ground
- #4 output
- #5 N/C
- #6 Vcc

Output inhibit:

- #1 high: output oscillation
- #1 low: output high impedance

Tape and reel dimensions(mm)

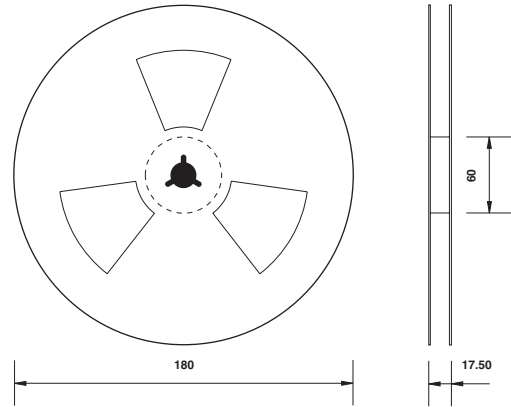

Centre hole diameter 13.0mm, slot width 2mm spaced at 120°
Reel quantity 1000 pieces, leader tape 400mm minimum
Trailer tape: 10 empty compartments minimum

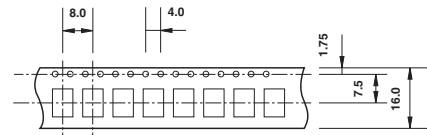

Tape transport hole diameter 1.5mm, 4.0mm pitch
Compartment size 8.18mm x 5.56mm, depth 2.16mm
Component spacing on 8.0mm pitch

Environmental test conditions

Mechanical shock	1500g, half sine wave, 0.5ms, 3 directions	MIL STD 883D 2002.3, condition A
Thermal shock	(-55 ~ +125)°C, 20 cycles	MIL STD 883D 1011.9, condition B
Vibration	(10 ~ 2000)Hz, 1.25mm, sine wave, 20g, each of three planes, duration 4 hours	MIL STD 883D 2005.2, condition B
Solderability	+245°C \pm 5°C, 5 seconds \pm 0.5 seconds	MIL STD 883D 2003.7
Fine leak	Mass spectrometer leak rate less than 2 ¹⁰⁻⁸ atm.cc/sec. helium	MIL STD 883D 1014.9, condition A
Gross leak	Leak test in de-ionised water, vacuum 70cm/Hg	
Humidity	85% relative humidity, +85°C, 500 hours	JIS-C 7022 B-5, condition C