

Series OS400-15 (5.0 ~ 50.0)MHz

- # sine wave, CMOS output
- # ± 0.005 ppm accuracy
- # excellent phase noise
- # extremely low ageing



Standard options:

frequency range:	(5.0 ~ 50.0)MHz		
accuracy codes:	(A)	(B)	(C)
temperature tolerance	± 0.005 ppm	± 0.01 ppm	± 0.02 ppm
temperature range	(0 +50) $^{\circ}$ C	(-10 +60) $^{\circ}$ C	(-20 +70) $^{\circ}$ C
output codes:	(S)	(L)	
output	sine wave, 0dBm into 50 Ω harmonics -30dBc max.	CMOS 15pF, 45% ~ 55% <2ns max. rise and fall	
supply voltage codes:	(V1)*	(V2)*	(V3)*
supply voltage	+3.3Vd.c.	+5.0Vd.c.	+12.0Vd.c.
trim reference option*	+3.0Vd.c.	+4.5Vd.c.	+4.5Vd.c.

* add suffix (R) for V_{ref} output on pin #5

Generic specification:

stability:	
against supply voltage change	± 0.002 ppm max. for $V_{CC} \pm 5\%$
against load change	± 0.002 ppm max. for load $\pm 10\%$
aging short term	± 0.0005 ppm max. per day after 30 days continuous operation
aging long term	± 0.1 ppm max. first year
voltage trim V_t	± 0.5 ppm min. typical, linearity $\pm 5\%$
trim input impedance	100K Ω min.
power supplies:	
supply voltage V_{CC}	+3.3Vd.c. +5.0Vd.c. +12.0Vd.c.
start up current at min. temp. range	900mA max. 600mA max. 300mA max.
quiescent current at max. temp. range	320mA max. 220mA max. 120mA max.
warm up time	5 minutes max. to within 0.1ppm of nominal
insulation resistance	500Meg Ω min., 100Vd.c.
phase noise:	
single sideband, 1Hz bandwidth	-110dBc/Hz, $f_o + 10$ Hz -135dBc/Hz, $f_o + 100$ Hz -155dBc/Hz, $f_o + 1$ kHz
temperature:	
operating range	(0 +50) $^{\circ}$ C (-10 +60) $^{\circ}$ C (-20 +70) $^{\circ}$ C
storage range	(-40 +125) $^{\circ}$ C (-40 +125) $^{\circ}$ C (-40 +125) $^{\circ}$ C

Series OS400-15

Environmental conditions:

mechanical shock: MIL standard 202F, method 213, condition J

thermal shock: MIL standard 202F, method 107, condition A

vibration: MIL standard 202F, method 204, condition B

solderability: 5 seconds max. at +230°C, 3 seconds max at +350°C

Marking:

frequency, date code, serial number on high temperature metalised polyester label

Ordering code:

standard specification: OS400-15 A S V2* - 10.00M

OS400-15 = series generic code

A temp. tol. and temp. range code: A = $\pm 0.005\text{ppm}(0 + 50)^\circ\text{C}$

S output code: S = sine wave output, 0dBm into 50Ω

V2* supply voltage code: V2 = +5Vd.c. supply

*Add suffix (R) for V_{ref} output on pin #5

10.00M output frequency: 10.00M = 10.000MHz

custom specification: part number issued with custom specification and drawing

Dimensions(mm):

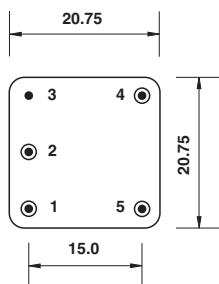
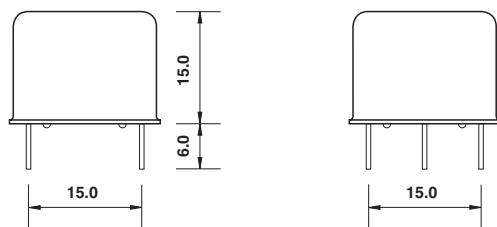

Pins viewed from bottom
pin diameter 0.45mm

Pin connections:

- #1 +V_{CC}
- #2 output
- #3 ground/case
- #4 trim
- #5 n.c. or trim reference voltage*

Test circuit:

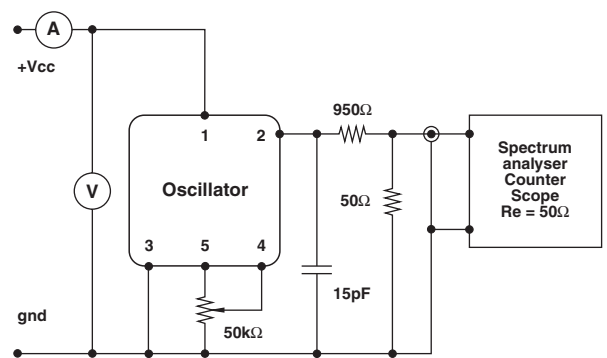

Test circuit includes a 20:1 step down into a matched 50Ω load